

Gas Spring Removal and Replacement

IMPORTANT BEFORE YOU BEGIN

Read these instructions and warnings completely before installation.

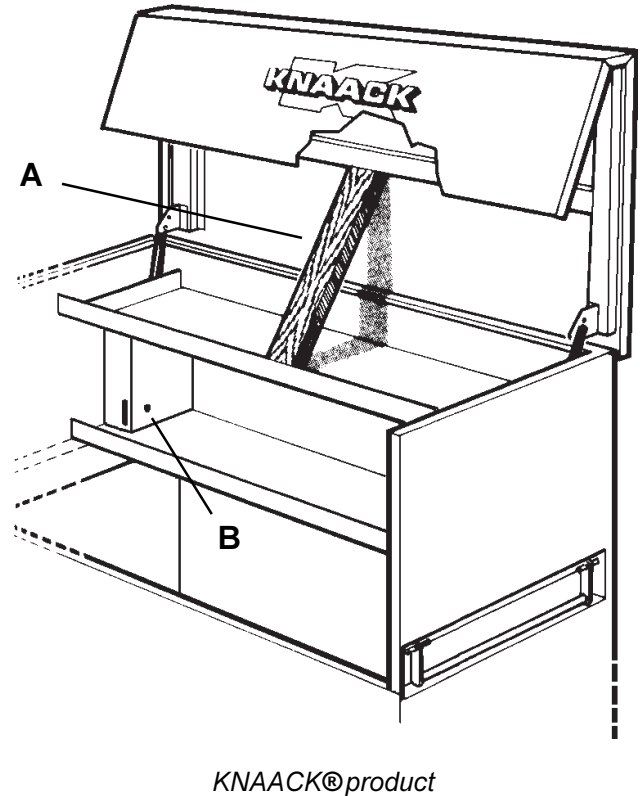
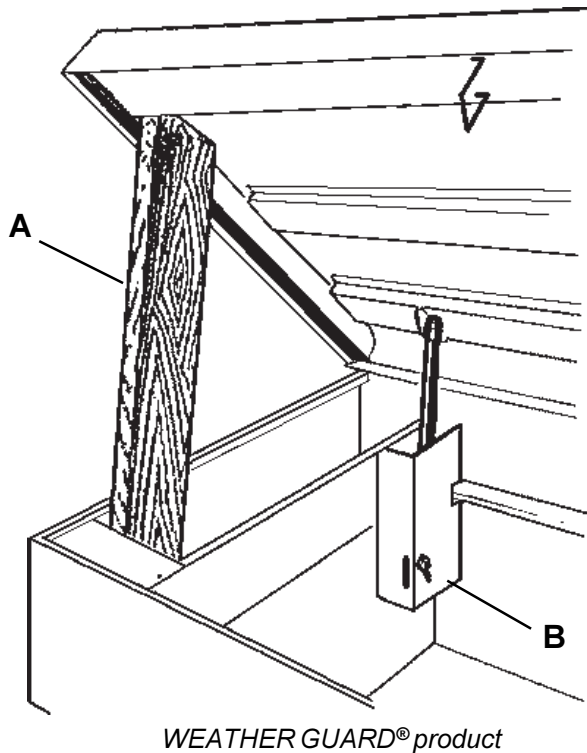

Figure 1.

⚠ WARNING

Possible accidental cover closure can occur from cover movement during Gas Spring removal and replacement. The cover must be securely propped in the up position, and we strongly suggest that another person helps steady the cover. Accidental cover closure, can cause head, arm, or other serious personal injuries.

TOOLS REQUIRED

- Screwdriver - small straight blade
- 1/2" Open End Wrench (2)

Procedure for WEATHER GUARD® boxes and KNAACK® Models 69/79/89/90/91/119-01

1. To remove the Gas Spring from your product, begin by propping up the cover with a length of wood. (See Figure 1, Item A) to prevent it from falling when the spring is removed.

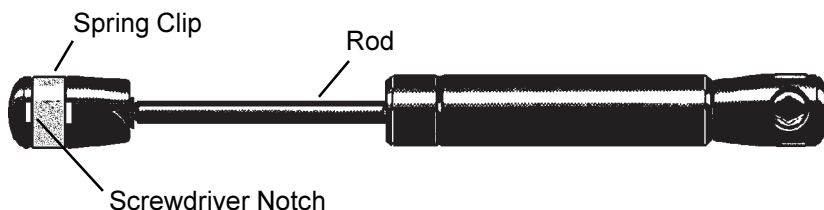
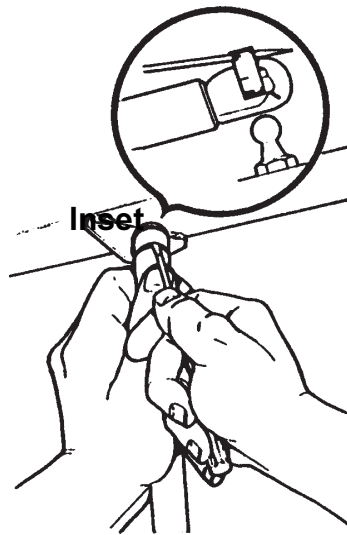
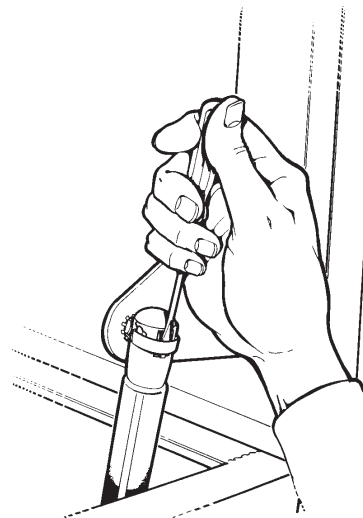

Figure 2. Gas Spring





WEATHER GUARD® product



KNAACK® product

Figure 3.

2. Loosen, but do not remove, the lower ball stud nut. To do this, access the hex of the ball stud through the slot in the gas spring guard and hold the ball stud with one wrench while loosening with the other (Figure 1, Item B). On WEATHER GUARD® crossboxes, the cover ball stud is the removable ball stud.

NOTE - When replacing Gas Spring, make sure the cylinder rod is facing down through the gas spring guard. On WEATHER GUARD® crossboxes, attach the rod end of the Gas Spring to the body ball stud. In this position the internal seals are always oil lubricated to prevent dry out. Dried out seals can crack and leak.

⚠ CAUTION

Be very careful when inserting the screwdriver blade under the clip. Brace your hands firmly to prevent injury in case the blade slips.

3. To remove the Gas Spring from the cover ball stud, insert the screwdriver blade into the notch (See Figure 2&3) and under the spring clip. Pry the clip up (Figure 3, Inset) until the ball stud is released and pull the Spring away.

7. To install a new Gas Spring, insert the ball stud on the rod end of the Gas Spring through the gas spring guard from the inside. Fasten the ball stud. To connect to the upper ball stud, simply push it into the upper ball stud while supporting the cover with your other hand. On WEATHER GUARD® products, loosen the lower ball stud nut, and adjust the cover for the desired height, then tighten the lower nut.

4. Re-check the security of the wood support holding the cover to prevent accidental cover closure.

KNAACK® MODEL 119-01

The replacement of the Gas Spring is the same as in the previous steps, except that the cover needs only be propped with the 119 prop arm. The prop arm safety pin **must** be in place before beginning the Gas Spring removal.

5. Remove the previously loosened lower ball stud nut (as in Step 2) and lift out the Gas Spring.

WEATHER GUARD® Van Racks

To replace these Gas Springs, simply remove them by prying the spring clip up until the ball stud is released. On aluminum van racks, be sure to install the plastic sleeve over the rod end of the Gas Spring before installing. To install the Gas Spring, simply push it onto the ball studs.

6. Remove the ball stud from the old Gas Spring and insert it into the new Gas Spring lower ball stud connector.

- NOTICE -

Any modification or unintended use of this product shall immediately void all manufacturers warranties. Manufacturer disclaims all liability for injuries to persons or property resulting from any modification to, or unintended use of this product.



Knaack LLC
ATTN: Warranty Claims
420 E. Terra Cotta Avenue
Crystal Lake, IL 60014

If you have any questions, please call toll free at 1-800-456-7865.
©2013 Knaack LLC

